

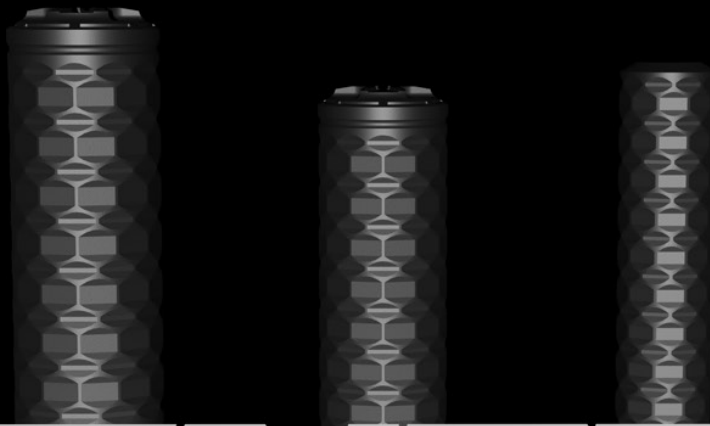

DIAMONDBACK
FIREARMS

Operating and Safety Instruction Manual



VENTRA

ABS SUPPRESSOR

MADE
IN THE **USA**

DIAMONDBACKFIREARMS.COM

CONTENTS

INTRODUCTION:	3
SAFETY INFORMATION:	4 – 5
OVERVIEW AND PRODUCT INFORMATION:	6
SUPPRESSOR PARTS LIST:	7
ASSEMBLY:	8
INSTALLATION:	9
BREAK-IN:	10
MAINTENANCE:	10
WARNING:	10
SERVICE:	11
LIMITED LIFETIME WARRANTY:	12
NOTES:	12

WARNING!

Please read this manual before taking your DIAMONDBACK SUPPRESSOR product out of the box. It is vital to your safety and the safety of others that you understand and adhere to the information contained in this manual, as well as information supplied by the manufacturer of the firearm and ammunition.

INTRODUCTION

CONGRATULATIONS!

You are now the owner of a **DIAMONDBACK FIREARMS, LLC.** suppressor. With proper maintenance and care, it will serve you for many years to come.

This manual provides the necessary information you need to know to use your suppressor safely and effectively. Should you have any questions or comments about this suppressor or its use and maintenance, or if you need more information about other **DIAMONDBACK FIREARMS, LLC.** products and accessories, please write or call:

DIAMONDBACK FIREARMS, LLC.

Customer Service Dept.

3400 Grissom Pkwy.

Cocoa, FL 32926

1.877.997.6774

California Proposition 65 Warning

“Discharging firearms in poorly ventilated areas, cleaning firearms, or handling ammunition may result in exposure to lead and other substances known to cause birth defects, reproductive harm, and other serious physical injury. Have adequate ventilation at all times. Wash hands thoroughly after exposure.”

SAFETY INFORMATION

Before you remove your new **DIAMONDBACK FIREARMS, LLC.** suppressor from the box, please read the following information. It is vital to both your safety and the safety of others.

FIREARM SAFETY IS YOUR RESPONSIBILITY.

WARNING: YOU MUST FOLLOW ALL OF THESE SAFETY RULES TO ENSURE THE SAFE USE OF YOUR SUPPRESSOR. FAILURE TO FOLLOW THE INSTRUCTIONS AND WARNINGS CONTAINED

IN THIS MANUAL COULD CAUSE SERIOUS INJURY OR DEATH TO YOU OR OTHERS. DAMAGE TO PROPERTY MAY ALSO OCCUR.

TREAT EVERY FIREARM AS IF IT WAS LOADED. ALWAYS KEEP YOUR FIREARM POINTED IN A SAFE DIRECTION. Never point a firearm at anyone or anything you do not intend to shoot, whether or not the firearm is loaded. This is particularly important when loading, unloading, or field-stripping the gun. ALWAYS control the direction of your firearm.

Verify your ammunition meets industry specifications (SAAMI and/or NATO) and it matches the firearm and suppressor caliber. Any modifications made to the suppressor that change the caliber or threading will VOID the warranty and any liability on **DIAMONDBACK FIREARMS, LLC.**

Before attaching your new suppressor, ensure your firearm is **NOT LOADED AND POINTED IN A SAFE DIRECTION.** Remove the magazine, open the action, and physically/visually inspect the chamber to verify there are no obstructions or live rounds in your firearm.

When mounting the suppressor, verify it is properly aligned with the firearm barrel. The suppressor must be fully shouldered on the barrel, and there should be no visible gap between the mount and barrel shoulder. The suppressor should also be fully tightened and not loose on the threads. Failure to properly mount the suppressor could result in serious loss of suppressor performance and/or bodily injury.

Firing many rounds will cause the suppressor to reach high temperatures, use caution when removing the suppressor immediately after firing. It is recommended to wait or use heat-resistant gloves to avoid burns or other injuries.

Suppressors reduce muzzle exit noise and flash; however, they do NOT guarantee hearing safety, always ensure all individuals around the firearm, including the shooter, are wearing adequate hearing protection.

FIREARM SAFETY IS YOUR RESPONSIBILITY.



SAFETY INFORMATION

NEVER ALTER ANY COMPONENTS OR FEATURES OF YOUR SUPPRESSOR.

Only use clean, dry, high-quality commercially manufactured ammunition that is in excellent condition and is the correct caliber for your firearm and suppressor.

Poor-quality ammunition may not meet industry specifications (SAAMI and/or NATO), may exceed pressure limits, and may be unsafe for your firearm or suppressor.

Never use ammunition where the pressure levels exceed industry standards. **DIAMONDBACK FIREARMS, LLC.** will not be held liable for any personal injury, property damage, or consequential damages if faulty ammunition is used in **DIAMONDBACK FIREARMS, LLC.** suppressors.

Never take medications, drugs, or alcohol when handling firearms.

Never discharge a firearm, even one equipped with a suppressor, without wearing proper protective equipment. Always wear shooting glasses and hearing protection.

Do not allow anyone to handle or attempt to fire a **DIAMONDBACK FIREARMS, LLC.** suppressor until they have read and understand this manual and the procedures for safe operation.

Before the suppressor left the factory, it was carefully inspected and packaged. **DIAMONDBACK FIREARMS, LLC.** cannot control product handling after it leaves the factory; therefore, please examine this suppressor carefully at the time of purchase to ensure that it is undamaged.

The use of NON-SAMMI Spec ammunition will void the suppressor's warranty.

OVERVIEW AND PRODUCT INFORMATION

The Diamondback Ventra suppressor line was designed and built for shooters who demand durability, repeatable performance, and proven reliability in the field. American-made and American-engineered, our suppressors combine military-grade materials with purpose-driven design. The result is compact suppression that withstands sustained use.

All Ventra models use Inconel 718 for critical internal components. Inconel 718 is a military and aerospace-grade material chosen for high-temperature strength and long-term dimensional stability. Exterior components utilize 17-4 stainless steel where applicable, along with a Cerakote finish, for enhanced corrosion resistance and rugged wear. The DBS-30i and DBS-556i incorporate Diamondback Pressure Venting Technology, or PVT, to reduce backpressure and blowback for cleaner cycling on semi-auto and full-auto platforms. The DBS-22i offers a compact and lightweight option for pistol-caliber and rimfire hosts.

Ventra design priorities:

- Low backpressure for smoother cycling and reduced blowback on PVT models.
- Compact footprint to preserve rifle balance and handling.
- Military-grade materials for heat resistance and long service life.
- Rugged finishes and conservative aesthetics for professional use.

Model specifications:

DBS-30i

- Caliber rating: .300 RUM
- Overall length (w/o mount): 6.130 in
- Length with direct-thread mount: 6.505 in
- Added length to firearm: 5.882 in
- Diameter: 1.64 in
- Weight (body): 16.0 oz
- Direct-thread adaptor weight: 1.89 oz
- Materials: Inconel 718 core, 17-4 stainless housing
- Mount: Direct Thread HUB adaptor, muzzle thread 5/8-24
- HUB compatible: Yes
- Full-auto rated: Yes
- Finish options: Cerakote Armor Black, Cerakote FDE, adaptor Black Nitride+

DBS-556i

- Caliber rating: 5.56 x 45 mm
- OAL (w/o mount): 5.336 in
- Length with direct-thread mount: 5.711 in
- Added length to firearm: 5.088 in
- Diameter: 1.55 in
- Weight (body): 11.84 oz
- Direct-thread adaptor weight: 1.89 oz
- Materials: Inconel 718 core, 17-4 stainless housing
- Mount: Direct Thread HUB adaptor, muzzle thread 1/2-28
- HUB compatible: Yes
- Full-auto rated: Yes
- Finish options: Cerakote Armor Black, Cerakote FDE, adaptor Black Nitride+

DBS-22i

- Caliber rating: 5.7 x 28 mm (.22 class hosts)
- Length with direct-thread mount: 5.625 in
- Added length to firearm: 5.5 in
- Diameter: 1.125 in
- Weight (body): 5.85 oz
- Materials: Inconel 718 core
- Mount: Direct thread, muzzle thread 1/2-28
- HUB compatible: No
- Full-auto rated: Yes
- Finish options: Cerakote Armor Black, Cerakote FDE, adaptor Black Nitride+



SUPPRESSOR PARTS LIST

DBS-556i Parts List

1. Suppressor Body
2. Direct Thread Mount
3. Wrench

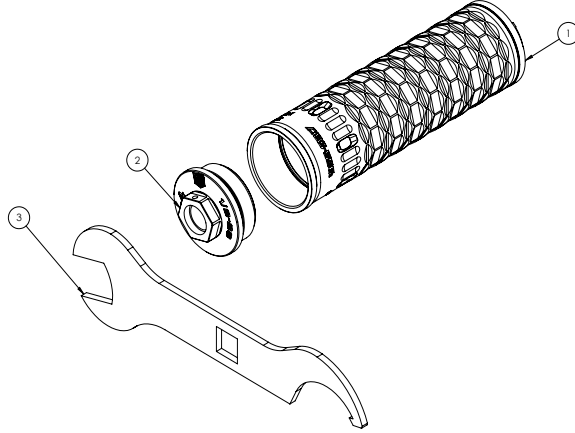

DBS-30i Parts List

1. Suppressor Body
2. Direct Thread Mount
3. Wrench

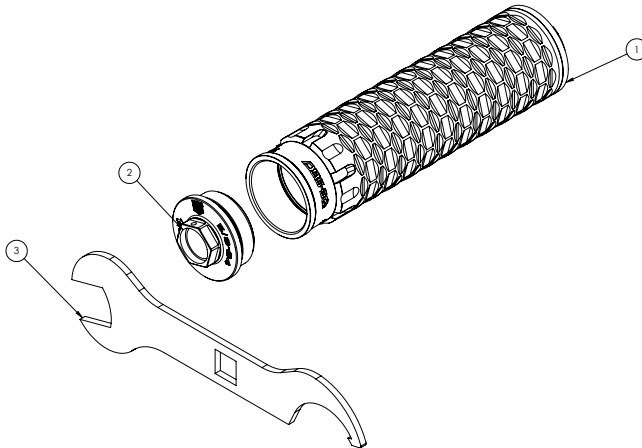

DBS-22i Parts List

1. Wrench
2. Suppressor

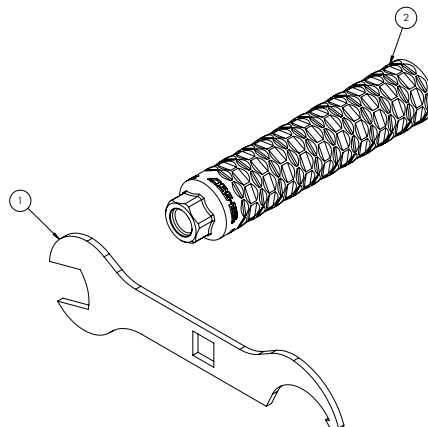

ASSEMBLY

DBS-556i & DBS-30i:

1. Hand-tighten the Direct Thread Mount onto the Suppressor Body. Be careful not to cross-thread the parts. (See Figure 1).

2. Using the supplied Wrench, 3/4 drive socket, or 3/4 crescent wrench on the Direct Thread Mount while holding the Suppressor Body with a strap-wrench, vice with non-marring jaws, by hand, or in any way that does not damage the finish; tighten as follows. (See Figure 2).

- a. 75% tight, or about 25ft-lbs
- b. loosen the Direct Thread Mount
- c. re-tighten using liberal force, or about 35 ft-lbs.

A 1/2 drive torque wrench may be used in conjunction with the supplied Wrench to ensure proper torque.

3. To remove the Direct Thread Mount from the Suppressor Body, follow the above steps in the reverse order.

Note: The spanner end of the supplied Wrench can be used to hold the Suppressor Body in place via the integral notches while a 3/4 drive socket or crescent wrench is used to tighten the Direct Thread Mount. (See Figure 3). You may find this method more conducive to field use; however, it is not preferred, as the Wrench may cause damage to the finish on the Suppressor Body.



Figure 1



Figure 2



Figure 3

DBS-22i

Your DBS-22i is a single unit and requires no assembly. It is ready to be installed onto your firearm. The DBS-22i cannot be disassembled but is serviceable via the **MAINTENANCE** instructions in this manual.

INSTALLATION

DBS-556i & DBS-30i

Once the suppressor is assembled, install the suppressor assembly on the firearm as follows:

1. With your firearm pointed in a safe direction, remove the magazine, open the action, and physically/visually inspect the chamber to verify there are no obstructions or live rounds in your firearm.

2. Hand-tighten the suppressor assembly to the barrel of your firearm. Be careful not to cross-thread the parts. (See Figure 4).

3. Use the Wrench to firmly tighten the suppressor assembly onto the barrel, via the hex head on the Direct Thread Mount or the integral notches (See Figure 4). Ensure the suppressor assembly is fully seated onto barrel shoulder and there is no visible gap, be careful not to overtighten. (See Figure 6 & Figure 7).

4. Ensure the bore of the firearm and the bore of the suppressor are properly aligned using a suppressor alignment rod. (See Figure 8).

To remove the Suppressor from the firearm, follow the above steps in the reverse order.

DBS-22i

1. With your firearm pointed in a safe direction, remove the magazine, open the action, and physically/visually inspect the chamber to verify there are no obstructions or live rounds in your firearm.

2. Hand-tighten the Suppressor to the barrel of your firearm. Be careful not to cross-thread parts together. (See Figure 4).

3. Use the Wrench to firmly tighten the Suppressor onto the barrel, via the hex head integral to the back of the Suppressor. Ensure the Suppressor is fully seated onto the barrel shoulder and there is no visible gap. Be careful not to overtighten. (See Figure 6 & Figure 7).

4. Ensure the bore of the firearm and the bore of the suppressor are properly aligned using a suppressor alignment rod. (See Figure 8).

To remove the Suppressor from the firearm, follow the above steps in the reverse order.



Figure 4



Figure 5



Figure 6



Figure 7



Figure 8

BREAK-IN

During initial use (first few heat cycles), it is normal for the suppressor to emit an odor or smoke. This will dissipate after several firing sessions. It is always recommended to use your firearms and suppressor in a well-ventilated area.

MAINTENANCE

DIAMONDBACK FIREARMS, LLC. suppressors require minimal maintenance. Periodically remove the Direct Thread Mount from the Suppressor Body (if applicable) and use a standard gun cleaning solvent and brush to remove any carbon buildup from the threads.

Soak the suppressor in suppressor solvent, like Breakthrough Suppressor Cleaner, every 300-400 rounds for several hours. The suppressor is designed to evacuate liquid from the aft end. Position the suppressor muzzle up to drain. Remove any buildup by blowing it out using compressed air or simply shooting rounds through the suppressor.

The suppressor is made from corrosion-resistant material, and the integrity of its coating is not necessary for proper function. However, to keep the suppressor in good visual condition, care should be taken not to damage the coating. The exterior of the suppressor is covered in a high-temperature Cerakote. While this coating is generally rugged, be careful not to use solvents or cleaning methods that are not compatible with Inconel 718, 17-4 Stainless Steel, or Cerakote (C-Series). It is recommended to use a light amount of lubricant and a microfiber towel to remove any fouling on the suppressor's exterior surfaces. Do not use CLR to clean your Suppressor or Direct Thread Mount.

Despite proper maintenance procedures, it is normal to see wear, scratches, or chips, in the finish of the suppressor from use and handling.

A small amount of smoke may be present during use after cleaning the suppressor or after cleaning the firearms with the suppressor attached. This is normal. As a result of the elevated temperatures that suppressors experience during use, any solvent or lubricant left on or in the suppressor will vaporize. To minimize this, remove the suppressor before cleaning the firearm. After cleaning the suppressor, blow out any excessive solvent, dunk the suppressor in a mild degreaser, and allow it to dry. Lubricating the suppressor is not recommended/required.

WARNING

ALTERATIONS & MODIFICATIONS

Altering or modifying parts is dangerous and will VOID the product's warranty. This **DIAMONDBACK FIREARMS, LLC.** suppressor was manufactured to perform properly with the original parts as designed. It is your duty to ensure that any parts you purchase are specifically designed for this product, are installed correctly, and that neither replacements nor originals are altered or modified. Your **DIAMONDBACK FIREARMS, LLC.** suppressor is a complex, precision tool with parts whose proper relationships must be maintained for proper and safe operation. Putting a suppressor together incorrectly or with improper or modified parts can cause malfunctions, which may result in damage to the suppressor and/or other personal property and may also result in serious personal injury or death to you and/or others.

Always have any work other than what is described in this manual performed by a qualified gunsmith or by **DIAMONDBACK FIREARMS, LLC.**; doing otherwise will void your product's warranty.



SERVICE

Should your suppressor need repair, it should be returned to the factory.

When shipping the suppressor, be sure to adhere to the following rules:

Federal Firearms Licensees are required to send an updated copy of their FFL with the return of a repair.

The suppressor and all components must be shipped in a secure, well-padded cardboard box.
Please do not ship with ammunition, it will not be returned.

You are responsible for knowing your state and federal firearm laws.

Individuals who wish to return the suppressor for service can do so by shipping it to the address below.
No return authorization number is required.

Include a letter of instruction, your full name, address, telephone number, and the suppressor's serial number. This will ensure prompt service and handling. Once your suppressor has been received, any work other than warranty work will be quoted. You will be notified of full charges, and no work will commence before your approval of the quote has been obtained.

DIAMONDBACK FIREARMS, LLC. accepts payments in the form of money orders, American Express, Discover, Mastercard, and Visa. Please return your suppressor to:

Diamondback Firearms, LLC.
Service Dept.
3400 Grissom Pkwy.
Cocoa, FL 32926
1.877.997.6774

DIAMONDBACK FIREARMS, LLC. LIMITED LIFETIME WARRANTY

This "Limited Lifetime Warranty" has been drafted to comply with the MAGNUSON-MOSS WARRANTY FEDERAL TRADE COMMISSION IMPROVEMENT ACT, which is effective for goods manufactured on or after December 31, 1976. DIAMONDBACK FIREARMS, LLC. warrants that this suppressor was originally manufactured free from defects in material and workmanship.

DIAMONDBACK FIREARMS, LLC. agrees to correct any defect in material and/or workmanship for the original purchaser by repair or replacement ONLY. Proof of purchase IS required. A service or handling charge may be applied at the company's discretion.

DIAMONDBACK FIREARMS, LLC. will not be responsible for defects resulting from careless handling, unauthorized adjustments or modifications, corrosion, neglect, abuse, failure to provide reasonable and necessary maintenance as described by this owner's manual. Damage caused by hand-loaded and/or reloaded or improper ammunition or damage caused from firing with any obstruction in the barrel, will not be warranted. This warranty does not apply to ordinary wear and tear of any parts, including metal, plastic, or any other material used to manufacture this product, as well as all surface finishes. DIAMONDBACK FIREARMS, LLC. does not warranty aftermarket parts or damage or issues caused by them.

Under no circumstances shall DIAMONDBACK FIREARMS, LLC. be responsible for incidental or consequential damages with respect to economic loss or injury or property damage, whether as a result of breach of express or implied warranty, negligence or otherwise. Some states do not allow the exclusion or limitation of incidental or consequential damages, so the above limitation or exclusion may not apply in certain cases.

If you need to return your suppressor to DIAMONDBACK FIREARMS, LLC. for warranty or service-related claims, please refer to the shipping instructions in the SERVICE section of this manual.

This DIAMONDBACK FIREARMS Operating and Safety Instruction Manual should be downloaded, printed, and always be kept with your suppressor, and in case of sale or transfer, should be passed on to subsequent owners.

Model: _____

Serial Number: _____

Sold To: _____

Date Sold: _____

NOTES: _____

